

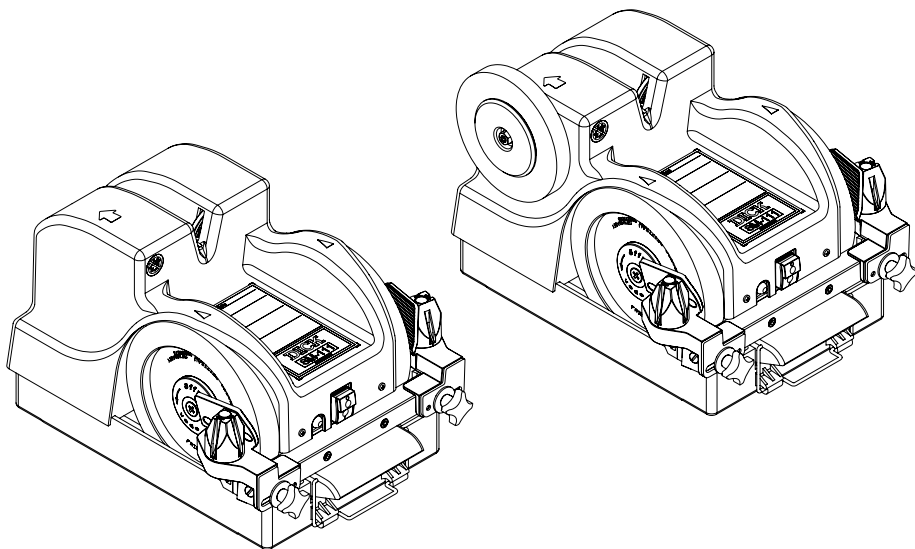

DICK



Traditionsmarke der Profis



Operating instructions (Translation)

Knife grinding and honing machine

SM-110

Prod. no. 9 8200 000

Prod. no. 9 8200 010

1~230 V – 50/ 60 Hz

1~115 V – 60 Hz

SM-111

Prod. no. 9 8210 000

Prod. no. 9 8210 010

1~230 V – 50/ 60 Hz

1~115 V – 60 Hz

Manufacturer and customer service address

Friedr. Dick GmbH & Co. KG
Postfach 1173
73777 Deizisau, Germany
GERMANY



Also visit the Friedr. Dick YouTube channel:
<https://www.youtube.com/user/FriedrDick/videos>
Videos show the operation of the Friedr. Dick machines.

Copyright

© 2023 Friedr. Dick GmbH & Co. KG
These operating instructions are protected by copyright; all rights are reserved.
These operating instructions may not be reproduced or copied, either in full or in part, without the prior consent of Friedr. Dick GmbH & Co. KG.
Infringements are subject to compensation claims and can result in criminal prosecution.

Contents

1	User Information	5
1.1	General	5
1.2	Symbols and conventions	5
1.2.1	Instructions	5
1.2.2	Lists	5
1.2.3	Courses of action	6
2	Scope of supply	7
2.1	Package contents	7
2.2	Unpacking the machine	7
3	Environmental protection	8
4	Safety	9
4.1	Meaning of the warnings	9
4.1.1	Identification of risks of injury	9
4.1.2	Identification of property damage	9
4.1.3	Identification of additional information	9
4.1.4	Symbols for the safety instructions	9
4.2	Intended use	10
4.3	General safety instructions	11
4.4	Information signs on the machine	12
5	Design and function	13
5.1	Technical data	13
5.2	Design of knife grinding and honing machine SM-110 and SM-111	16
5.3	Function	17
6	Putting the machine into operation	18
6.1	Installing the machine	18
6.2	Filling cooling water	20
6.3	Connecting the machine	21
6.4	Adjusting the machine	22
6.4.1	Adjusting the knife guides (grinding angle)	22
6.4.2	Setting the honing wheels (only SM-111)	23
6.5	Control elements on the machine	24
6.6	Switching on the machine	25
6.7	Switching off the machine	27

7	Machining workpieces	29
7.1	Knife sharpening	29
7.2	Honing knives	30
7.3	Polishing the knife (only SM-111)	31
8	Servicing and maintenance	34
8.1	Clean the machine	35
8.2	Dressing the grinding wheel	36
8.3	Removing the grinding wheels	37
8.3.1	Additional steps if the grinding wheel is stuck	39
8.4	Installing the grinding wheels	39
8.5	Remove the honing wheels	40
8.6	Installing the honing wheel	42
8.7	Replacing the polishing wheel (only for SM-111)	43
8.8	Check and replace drive belt	44
8.8.1	Dismantling the housing	44
8.8.2	Checking the belt condition	45
8.8.3	Replacing the flat belt	45
8.8.4	Replacing the round belt	46
8.8.5	Installing the housing	46
8.9	Replacing water stripping brush	47
9	Fault – cause – remedy	50
10	Spare parts	51
11	Accessories	52
12	EC Declaration of Conformity	53

1 User Information

1.1 General

These operating instructions are part of the SM-110/-111 knife grinding and honing machine with the serial number given on the type plate (the type plate is located on the side underneath the guard).

These operating instructions must be kept within reach near the machine at all times. They contain important information for the safe, proper and economical use of the machine.

These operating instructions must have been read and understood by each person before this person may carry out the following work using the machine:

- Putting into operation
- Operation
- Servicing

NOTE



Avoid dangers and lower repair costs:

⇒ The operating instructions must be observed at all times while working on and with the machine.

The technical information and instructions for use in this operating instructions are up-to-date and correct on delivery of the machine. Friedr. Dick GmbH & Co. KG reserves the right to further develop the design and to make changes without notice.

All directional information refers to the view of the operator.

1.2 Symbols and conventions

1.2.1 Instructions

Sequences of actions, which must be carried out in the given order are specified as a numbered list:

1. Instruction step 1.
2. Instruction step 2.

1.2.2 Lists

Lists without a particular order that have to be followed are shown as a list with bullet points or indent markings:

- Property A
 - Detail 1
 - Detail 2
- Property B

1.2.3 Courses of action

The courses of action to be taken to avoid dangers or the required further procedure are marked with an arrow:

- ⇒ Procedure 1
 - Detail 1
 - Detail 2
- ⇒ Procedure 2

2 Scope of supply

2.1 Package contents

- Machine
- Operating instructions
- Short operating instructions
- Set of tools
- Dressing spindle complete
- Polishing paste (only for SM-111)
- Declaration of conformity (for 230 V version)

2.2 Unpacking the machine

1. Unpack the machine immediately after purchase
2. Check whether the machine has suffered any defects or damage during transport.
 - ⇒ Keep the original box for any necessary returns in order to prevent transport damage.
3. Check the package contents to ensure that the delivery is complete.
 - ⇒ Report missing parts/defects to your specialist dealer immediately. Complaints made at a later date can no longer be recognised.
 - ⇒ Keep the invoice during the warranty period as proof of purchase.
4. In case of complaints, write to your specialist dealer, enclose the original invoice and a precise description of the actual defects.
5. Before returning the product, wait for the specialist dealer's reply in order to initiate the necessary steps.
 - ⇒ Friedr. Dick GmbH & Co. KG does not pay any transport costs for returns that have not been explicitly approved.

IMPORTANT



DAMAGE IN CASE OF INCORRECT CONNECTION DATA

If the machine's connection data do not match those on site, the machine may be damaged.

- ⇒ Verify the connection data before putting it into operation for the first time (see "Type plate").
- ⇒ Do not put the machine into operation if the connection values on site are higher.

3 Environmental protection

NOTE



DISPOSAL

Used machines, replacement parts and packaging are made of recyclable materials.



⇒ The above materials must be disposed of independently (properly and in an environmentally friendly manner) and in accordance with the statutory regulations applicable in the relevant countries.

4 Safety

4.1 Meaning of the warnings

4.1.1 Identification of risks of injury

In these operating instructions, signal words such as DANGER, WARNING or CAUTION indicate the gradation of a possible risk of injury.

DANGER indicates an imminently hazardous situation which, if not avoided, will result in death or serious injury.

WARNING indicates a potentially hazardous situation which, if not avoided, may result in death or serious injury.

CAUTION indicates a potentially hazardous situation which, if not avoided, may result in minor or slight injury.

4.1.2 Identification of property damage

IMPORTANT indicates a potentially hazardous situation which, if not avoided, may result in property damage.

4.1.3 Identification of additional information

NOTE provides additional information and helpful tips for the safe and efficient use of the device.

4.1.4 Symbols for the safety instructions

Important or particularly useful information is highlighted using symbols so that it is readily recognised:



WARNING – Indicates a warning, which must always be noted and followed.



INSTRUCTION – Indicates instructions, which must be complied with for safety reasons.



NOTE, TIP – Indicates general information containing user tips and useful information.



Electric shock – warns of an electric shock that may cause serious injury or even death.



Read operating instructions – indicates that the operating instructions must be observed, as failure to do so may result in serious injury or even death.



Disconnect the mains plug – indicates that the mains plug must be disconnected before any maintenance or similar work is carried out.



Protect from moisture – indicates that the machine as well as the abrasive material must be protected from water, moisture and wetness.



Wear protective equipment – indicates that personal protective equipment, e.g. hearing protection and safety goggles, protective gloves or a hair net, must be worn.



4.2 Intended use

- The machines SM-110 and SM-111 are designed for commercial use only and are not intended for mobile use.
- The machines SM-110 and SM-111 may only be used for grinding and honing hand knives with a smooth cutting edge. Using corresponding DICK special accessories, household scissors can also be professionally sharpened (see 11 Accessories).
- The machines are designed exclusively for use in dry interiors at temperatures between +5 and +30 °C.
- Original spare parts and accessories from Friedr. Dick GmbH & Co. KG must exclusively be used.

Any other or additional use is deemed to be improper use.

- The machine must not be used, among other things, for grinding materials that produce harmful dusts.
- The machine must not be used for freehand grinding and honing of unlisted cutting, punching, splitting, chipping, scraping, marking and sewing tools and equipment, machine knives or dirty abrasive material.

The owner is responsible for any damage caused by improper use.

4.3 General safety instructions

WARNING



RISK OF INJURY DUE TO INCORRECT HANDLING

The incorrect handling of the machine (e.g. reaching into abrasives or polishes) may cause blunt injuries, abrasions or burns.



The machine may only be used by people who

- ⇒ have read and understood the operating instructions,
- ⇒ are familiar with the start-up, operation and maintenance of machines and the applicable accident prevention regulations,
- ⇒ recognise the dangers that occur during work and work reliably,
- ⇒ do not operate the machine outside the given power ranges (see 5.1 Technical data),
- ⇒ only operate the machine according to the approved applications (see 4.2 Intended use).

WARNING



RISK OF INJURY IN UNSUITABLE ENVIRONMENTS

Poor or excessively dark lighting or inadequate space to work may cause injuries.

Only use the machine

- ⇒ in good lighting conditions,
- ⇒ with adequate space to work.

4.4 Information signs on the machine

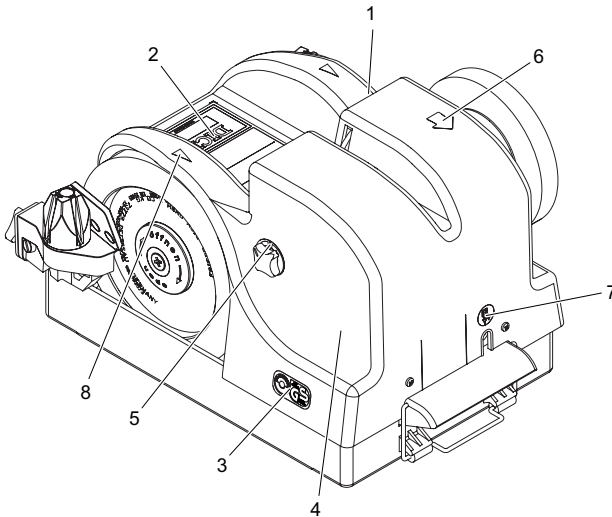

Image 1 – Information signs on the machine (here SM-111)

- [1-1] Protect against moisture
- [1-2] Short operating instructions
- [1-3] GS mark (for 230-V version)
- [1-4] Type plate underneath the hood
- [1-5] Star handle to set the honing angle (only for SM-111)
- [1-6] Direction of rotation of the polishing wheel (only for SM-111)
- [1-7] Pull the mains plug
- [1-8] Direction of rotation of the grinding wheel

5 Design and function

5.1 Technical data

Motor and electrical equipment 1~230 V:

	SM-110	SM-111
Power	0.13 kW	
Voltage	1~220-240 V	
Current intensity	0.9 A	
Frequency	50/60 Hz	
Degree of protection	IP 54	
Type of operation	S3-70 %	
Rated speed at 50 Hz	2700 min ⁻¹	

Motor and electrical equipment 1~115 V:

	SM-110	SM-111
Power	0.13 kW	
Voltage	1~115 V	
Current intensity	2.2 A	
Frequency	60 Hz	
Degree of protection	IP 54	
Type of operation	S3-70 %	
Rated speed at 60 Hz	3240 min ⁻¹	

Grinding wheel 1~230 V:

	SM-110	SM-111
Dimensions	200 × 40 × 20 mm	
Speed:	225 min ⁻¹	
Cutting speed	$V_c = 2.3 \text{ m/s}$	

Grinding wheel 1~115 V:

	SM-110	SM-111
Dimensions	200 × 40 × 20 mm	
Speed:	270 min ⁻¹	
Cutting speed	$V_c = 2.8$ m/s	

Honing wheel 1~230 V:

	SM-110	SM-111
Dimensions	75 × 6 × 20 mm	
Speed:	790 min ⁻¹	
Cutting speed	$V_c = 3.1$ m/s	

Honing wheel 1~115 V:

	SM-110	SM-111
Dimensions	75 × 6 × 20 mm	
Speed:	1000 min ⁻¹	
Cutting speed	$V_c = 3.9$ m/s	

Polishing wheel 1~230 V:

	SM-110	SM-111
Dimensions	-	150 × 20 × 30 mm
Speed:	-	1180 min ⁻¹
Cutting speed	-	$V_c = 9.3$ m/s

Polishing wheel 1~115 V:

	SM-110	SM-111
Dimensions	-	150 × 20 × 30 mm
Speed:	-	1500 min ⁻¹
Cutting speed	-	$V_c = 11.8$ m/s

Machine dimensions / weights

	SM-110	SM-111
Length	462 mm	
Width	337 mm	
Height	268 mm	293 mm
Weight	14.2 kg	15.4 kg

Emissions sound pressure level

	SM-110	SM-111
Emission sound pressure level L_{pA} when at idle	76 dB (A)	
Uncertainty K_{pA} when at idle	3 dB (A)	
Emission sound pressure level L_{pA} when grinding a hand knife	77 dB (A)	
Uncertainty K_{pA} when grinding a hand knife	3 dB (A)	

5.2 Design of knife grinding and honing machine SM-110 and SM-111

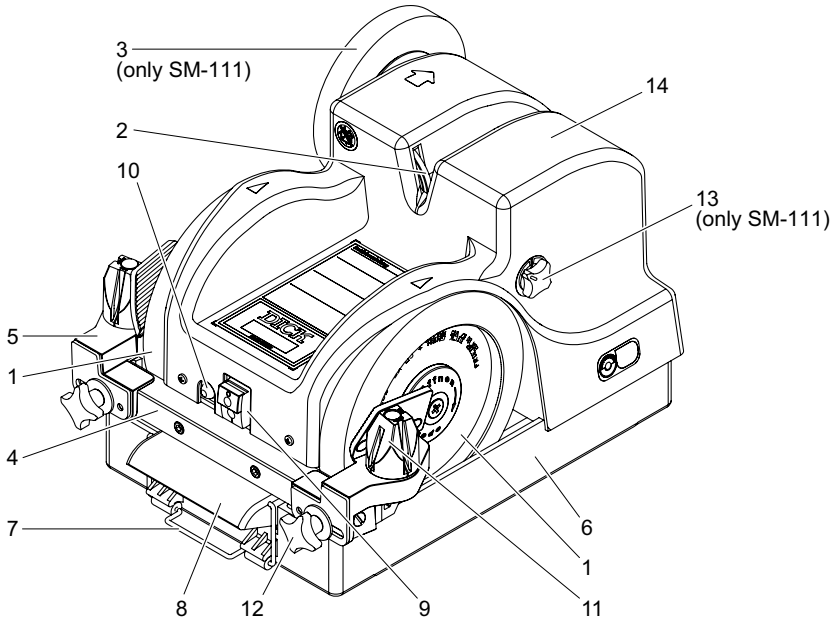

Image 2 – Design of the machine

- [2-1] Grinding wheels
- [2-2] Honing wheels
- [2-3] Polishing wheel (only for SM-111)
- [2-4] Guidance
- [2-5] Knife guide
- [2-6] Water tank
- [2-7] Clamp
- [2-8] Handles for lifting the machine
- [2-9] Main switch
- [2-10] Safety switch
- [2-11] Angle pyramid
- [2-12] Star handle screws
- [2-13] Star handle to set the honing angle (only for SM-111)
- [2-14] Housing

5.3 Function

The SM-110 consist of two, the SM-111 of three function groups.

Knife grinding and honing machine SM-110 and SM-111

SM-110 and SM-111 consists of a grinding device with two grinding wheels **[2-1]** and a honing device with two counter-rotating honing wheels **[2-2]**. The knife grinding and honing machine SM-111 also has a polishing wheel **[2-3]**.

The grinding wheels run in water. They can be turned over after the first side has worn out, thus doubling their service life (see 8.3 Removing the grinding wheels). The direction of rotation of the grinding wheels is directed against the knife edge.

On the guide **[2-4]** there is a knife guide **[2-5]** with holding magnets to hold the knife blade in place.

The honing wheels **[2-2]** are made of an extremely hard material composition. Therefore wear is so low that the honing wheels can be used for years during normal use. Please pay attention to the cleaning instructions for the care of the honing wheels (see 8.1 Clean the machine).

The individual assemblies of the machine, such as motor, honing device and knife guides, are attached to a torsion-resistant plastic chassis. The upper part of the machine is covered with a housing made of impact-resistant plastic.

The machine is positioned in a stable water tank **[2-6]** made from impact-resistant plastic, to which it is connected by two clamping brackets **[2-7]**. Two handles **[2-8]** make it easier to lift the machine out of the water tank.

The main switch **[2-9]** is used to switch the machine on and off. The safety switch **[2-10]** protects the motor from overload (see 6.5 Control elements on the machine).

The grinding angle can be set by turning the angle pyramid **[2-11]** (see chapter 9.2). The star handle screws **[2-12]** permit locking of the movable knife guides.

The SM-111 knife sharpening and honing machine also has a start handle **[2-13]** to set the honing angle (see 6.4.2 Setting the honing wheels (only SM-111)).

6 Putting the machine into operation

6.1 Installing the machine

WARNING



RISK OF INJURY IN THE EVENT OF SLIPPING, FALLING OR TILTING MACHINE

A slipping, falling or tilting machine can fall on hands or feet and cause serious injury.

- ⇒ Only place the machine on a stable, load-bearing table or other base that can support the weight of the machine.
- ⇒ The stand must not be mobile or fitted with wheels or castors.
- ⇒ The machine must stand on a flat, non-slip surface.

WARNING



RISK OF INJURY DUE TO IMPROPER POSTURE

A posture in which you cannot keep your balance or have to bend can lead to falling onto or into the machine or to tipping over with the machine, resulting in serious injuries.

- ⇒ Always adjust the height of the base to the height of the operator to ensure work is carried out in an upright posture with a secure footing that allows balance to be maintained.
- ⇒ Keep the area around the machine free from other equipment and bulky objects.

Only for SM-111

NOTE



PROTECT THE POLISHING WHEEL AGAINST MOISTURE

The polishing wheel swells when wet and becomes unusable.

- ⇒ Store the polishing wheel in a dry place and protect it against moisture.

Set up the machine at a non-slip, stable workplace with sufficient lateral clearance.

- Maximum installation height 70 cm
- Wall clearance at least 40 cm
⇒ This also permits long knives to be honed.

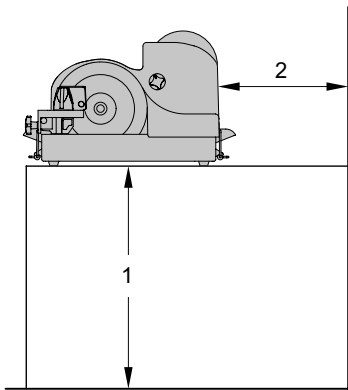

[3-1] Installation height
[3-2] Wall clearance

Image 3 – Installing the machine



6.2 Filling cooling water

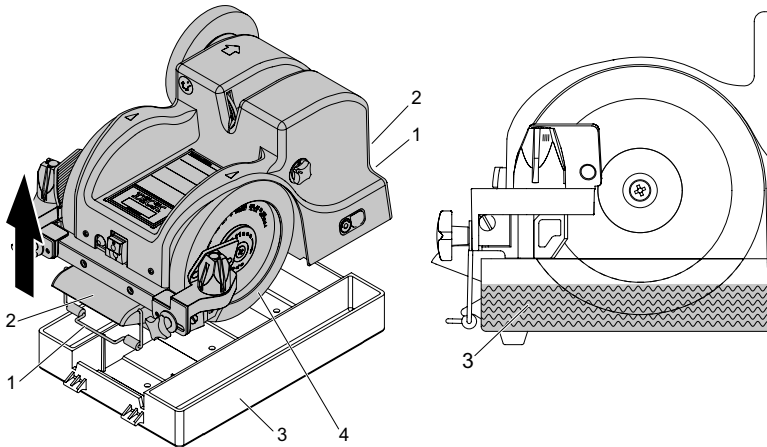

Image 4 – Filling cooling water

[4-1] Clamp

[4-2] Handles for lifting out the machine

[4-3] Water tank

[4-4] Lateral grinding surfaces

1. Switch off the machine, pull the mains plug.
2. Open the clamp **[4-1]**.
3. Lift the machine from the handles **[4-2]** out of the water tank **[4-3]**.
4. Fill the left and right chamber of the water tank with 2 to 2.5 cm of water.
Do not fill water into the central chamber.
5. Place the machine onto the water tank.
6. Close the clamp **[4-1]**.

NOTE



NEVER GRIND DRY

The water is used for cooling in order to prevent the cutting edge of the knife overheating during the grinding process.

6.3 Connecting the machine

DANGER



RISK OF ELECTRIC SHOCK

The electrical machine data must match the data of the mains supply. The connecting cable and plug must be in perfect condition.



- ⇒ When disconnecting the power connection, hold onto the plug, not the cable, and pull it out of the socket.
- ⇒ The machine may only be connected to sockets with protective earthing.
- ⇒ Connect the machine only when it is switched off.

WARNING



RISK OF INJURY DUE TO CARELESS SWITCHING ON

If the machine is plugged in when the mains switch is set to "1", it will start uncontrollably.

- ⇒ Before plugging in the mains plug make sure that the switch is set to "0".

1. Insert the mains plug.
2. Switch on the machine and test run it for one minute. In case of unusual behaviour, switch off the machine immediately and check all individual parts for proper condition and assembly.
3. Check the direction of rotation of the grinding wheels. The direction of rotation must correspond to the two marking arrows on the housing above the grinding wheels.

WARNING



RISK OF INJURY FROM KNIVES STRIKING BACK

In case of wrong direction of rotation, risk of accident due to knives striking back.

- ⇒ Immediately switch off the machine and send it to the manufacturer or supplier for inspection.

6.4 Adjusting the machine

CAUTION



RISK OF INJURY FROM ROTATING MACHINE PARTS

If the machine is accidentally switched on during adjustment work, there is a risk of injury due to rotating machine parts.

⇒ Disconnect the mains plug before carrying out any adjustment work.

6.4.1 Adjusting the knife guides (grinding angle)

The grinding angle (overall grinding angle A) can be set to 4 different angles: approx. 24°, 28°, 32° and 36°. Ex works, the grinding angle is set to 32°.

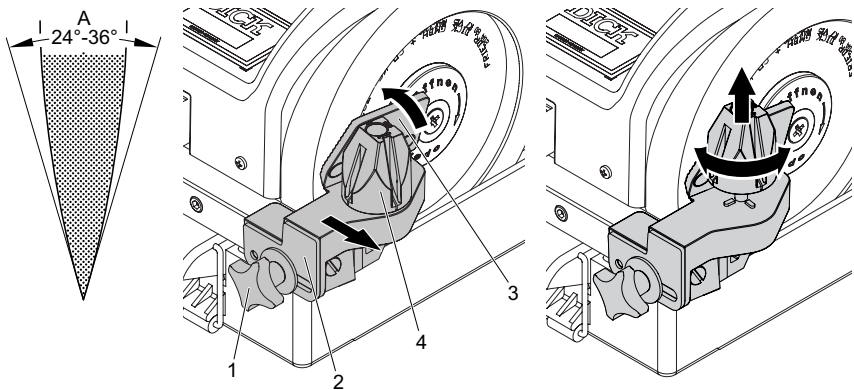

Image 5 – Adjusting the grinding angle

[5-1] Star handle screw

[5-2] Knife guide

[5-3] Contact surface

[5-4] Angle pyramid

[5-A] Overall grinding angle

1. Undo star handle screw [5-1], push knife guide [5-2] outwards until the stop.
2. Open the contact surface [5-3] in the direction of the grinding wheel until the spring is outside the groove of the angle pyramid [5-4].
3. Lift the angle pyramid upwards by hand and turn it to the desired grinding

angle position. The markings on the angle pyramid surfaces correspond approximately to the following overall grinding angles (A): I = 36°, II = 32°, III = 28°, IIII = 24°. The desired grinding angle surface of the angle pyramid must point in the direction of the grinding surface of the grinding wheel.

4. Fold back the contact surface **[5-3]** and snap in the angle pyramid.
 ⇒ For a symmetrical overall grinding angle (A), the grinding angle must be identical for both knife guides. To this end, repeat the setting on the opposite side.
5. For good and safe knife guidance during grinding, place the knife guides **[6-1]** as close as possible to the grinding wheels without touching them. To this end, loosen the star handle screw **[6-2]** and tighten it again after adjustment. The grinding angle setting does not change here.

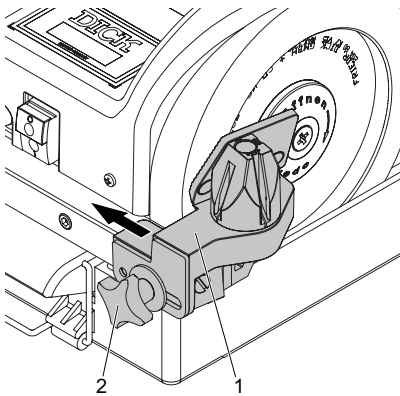

[6-1] Knife guide
[6-2] Star handle screw

Image 6 – Setting the knife guide

6.4.2 Setting the honing wheels (only SM-111)

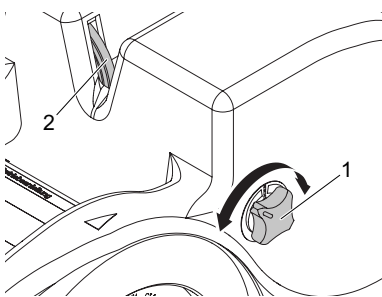

[7-1] Star handle
[7-2] Honing wheels

Image 7 – Adjusting the honing wheels

Using the star handle **[7-1]** on the right machine side, you can set the honing angle. Turning the star handle changes the centre distance of the two honing wheels **[7-2]** and thus the honing angle:

- Turn the star handle to the left = greater centre distance / smaller honing angle
- Turn the star handle to the right = smaller centre distance / larger honing angle

The honing angle must be greater than the grinding angle (see 6.4.1 Adjusting the knife guides (grinding angle)). We recommend to hone in the normal position of approx. 40°. At this angle, the outer diameter of the left honing wheel touches the marking circle **[8-A]** of the right honing wheel.

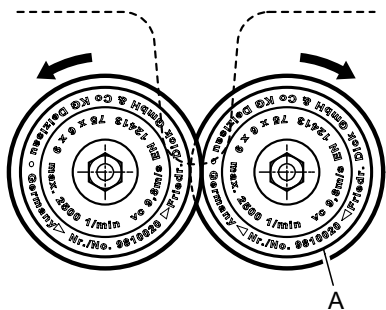

[8-A] Marking circle of the right-hand honing wheel

Image 8 – Honing wheel in normal position

The star handle **[7-1]** can be pulled off to protect against unintentional adjustment.

6.5 Control elements on the machine

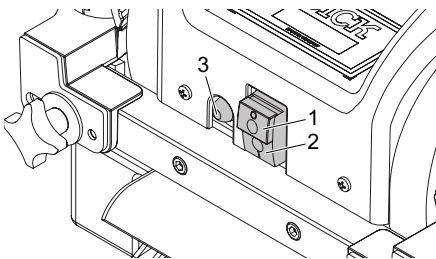

- [9-1]** Main switch off (0)
- [9-2]** Main switch on (I)
- [9-3]** Safety switch, overload protection

Image 9 – Main switch

In order to protect the motor from damage due to overload, the machine is equipped with an overload switch [9-3]. This triggers in the event of an overload. The switch button activates and interrupts the power supply to the motor. After pressing in the switch button, the machine is ready for operation again.

WARNING



RISK OF INJURY DUE TO UNINTENTIONAL START-UP

When the safety switch is pressed, there is the risk of unintentional start-up

- ⇒ Before pressing the safety switch, make sure that the main switch [9-1] is in the off (0) position

6.6 Switching on the machine

WARNING



RISK OF INJURY DUE TO DAMAGED OR INCORRECTLY MOUNTED MACHINE PARTS

Using the machine with damaged electric parts or power cables can cause injuries due to electric shocks or malfunctions. Damaged machine parts can be flung away.

- ⇒ Before each use, check the machine for the proper installation and functioning and for damage.
- ⇒ Above all, check the following parts for functioning and damage:
 - the grinding wheels and honing wheels,
 - the polishing wheel (only SM-111),
 - the power cable,
 - the main switch.
- ⇒ Replace damaged parts before using the machine again.

CAUTION**RISK OF INJURY DUE TO THE POOR HEALTH OF THE OPERATOR**

Lack of concentration, fatigue, illness, intoxication, mental disability and disabilities of the legs or arms result in an increased risk of injury.

- ⇒ People who work at the machine must be healthy and capable of concentrating.
- ⇒ Before starting work at the machine, ensure that you are in a stable position in which you can maintain your balance well.
- ⇒ When grinding and polishing, do not look away from the machine and the knife.

CAUTION**RISK OF INJURY WHEN TOUCHING ABRASIVES**

Touching the rotating machine parts when the machine is switched on will cause injuries.

- ⇒ Do not touch any abrasives while the machine is switched on.
- ⇒ Do not use any objects to brake rotating abrasives.
- ⇒ When switched on, the machine must be inaccessible to persons not working at the machine, especially to children.
- ⇒ Before leaving the work area, switch off the machine and disconnect the mains plug from the socket.
- ⇒ Do not touch rotating machine parts.

WARNING**RISK OF INJURY DUE TO IMPROPER POSTURE**

Rotating machine parts can catch unsuitable clothing or long hair and rotating abrasives can tear clothing. Flying abrasive particles can damage the eyes and loud machine noise can damage the ears. Sharp or hot knives can cause injuries to the hands.



- ⇒ Wear tight-fitting clothing.
- ⇒ Remove jewellery.
- ⇒ Wear a hair net on long hair.
- ⇒ Wear safety goggles and hearing protection.
- ⇒ Wear suitable protective gloves.

Switch on the machine as follows:

1. Insert the plug into the socket.
2. Press the I key [9-2] on the main switch.
3. Check the direction of rotation when starting up the machine.
⇒ The direction of rotation is given by arrows [10-1] on the covers.

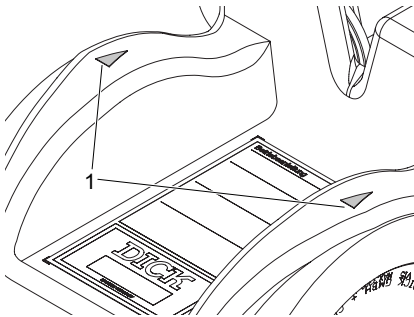

[10-1] Indication of the direction of rotation on the grinding wheels

Image 10 – Indication of the direction of rotation on the grinding wheels

6.7 Switching off the machine

1. Press the 0 key [9-1] on the main switch.
2. Wait until the machine has come to a complete stop.

DANGER



RISK OF ELECTRIC SHOCK

If the plug is removed from the socket by pulling the power cable, the connection between the plug and cable can be damaged and is therefore a substantial source of danger.



⇒ When disconnecting the power connection, hold onto the plug, not the cable, and pull it out of the socket.

3. Pull the mains plug out of the socket.
4. Clean the machine

WARNING**RISK OF INJURY DUE TO CARELESS SWITCHING ON**

If the machine is left unattended after grinding work, there is a risk of the machine being switched on by unauthorised/careless persons.

- ⇒ After carrying out grinding work, never leave the machine unsupervised unless the mains plug has been disconnected.
- ⇒ Place the machine in a safe location to which unauthorised persons do not have access.

7 Machining workpieces

IMPORTANT



DAMAGE TO THE ABRASIVES

Contaminated knives can destroy the grinding wheels.

⇒ Only machine clean knives.

IMPORTANT



RISKS OF BURNS DUE TO HOT SURFACES

The surfaces can heat with long-term use. This can cause burns and damage the machine.

⇒ Switch off the machine after 10 minutes at the latest.

7.1 Knife sharpening

In the case of knives that have previously been ground in another way (e.g. on a grinding belt), increased grinding effort must be expected during the first sharpening.

NOTE



Knife blades that have not been cleaned contaminate the grinding wheels.

⇒ Before grinding, carefully clean the knife blade.

1. If necessary, adjust the grinding angle (see 6.4.1 Adjusting the knife guides (grinding angle)).
2. Switch on the machine (see 6.6 Switching on the machine).

NOTE



We recommend marking the surface to be sharpened with a permanent marker before grinding.

3. Position the knife on the machine so that the cutting edge **[11-1]** points towards the grinding wheel or downwards.

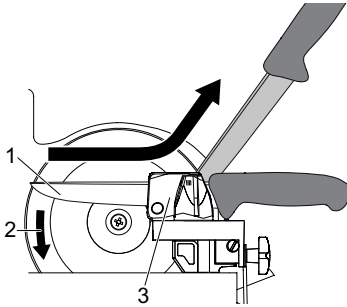

- [11-1] Knife cutting edge
- [11-2] Direction of rotation of the grinding wheel
- [11-3] Holding magnet (contact surface)

Image 11 – Positioning of the knife to the grinding wheel

4. Pull the knife alternately left and right between grinding wheel and the holding magnet **[11-3]** (contact surface) until the cutting edge is ground along its entire length.
 - ⇒ The grinding burrs will be removed during the subsequent honing process (see 7.2 Honing knives).
5. Start the pulling movement at the handle and continue to the tip of the blade without interruption.
 - ⇒ If the pulling movement is interrupted, nicks can form in the cutting edge.

NOTE



Do not tense up when holding the blade. After sharpening, the knife must have continuous, equally wide bevel on both sides of the blade.

7.2 Honing knives

NOTE



Knife blades that have not been cleaned contaminate the honing wheels.
 ⇒ Before grinding, carefully clean the knife blade.

1. If necessary, adjust the honing angle (see 6.4.2 Setting the honing wheels (only SM-111))
2. If necessary, switch on the machine (see 6.6 Switching on the machine)

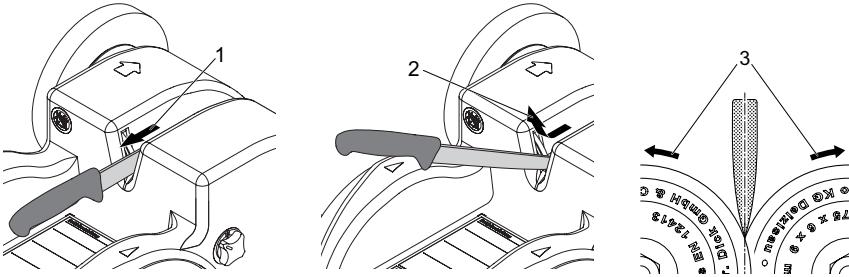

Image 12 – Positioning the knife to the honing wheels

[12-1] Honing direction

[12-2] Lift in the front blade area

[12-3] Direction of rotation of the honing wheels

3. Starting at the handle, pull the knife through the honing wheels with light pressure and without interruptions **[12-1]**.
4. In the front area of the blade, lift the handle according to the course of the cutting edge **[12-2]**.
 - ⇒ If the pulling movement is interrupted, nicks can form in the cutting edge.
5. Make two to three more passes with decreasing pressure.
6. Finally, hone twice without pressure - the knife's own weight is sufficient.
7. Clean the knife after honing.

NOTE



If the burr is not removed or the knife is not sharp, the angle has been set too acute or too little has been ground beforehand.

7.3 Polishing the knife (only SM-111)

After honing, polish the knife cutting edge briefly on the felt polishing wheel.

WARNING



RISK OF INJURY DUE TO INCORRECT POSITIONING

When the knives are positioned against the direction of rotation, the workpieces can be caught and flung from the machine.

⇒ Never place knives against the direction of rotation on the polishing wheel.

CAUTION

BURNS FROM HOT BLADES. THE BLADE MAY BECOME HOT DURING POLISHING.

If necessary, let the blade cool down during the polishing process.

NOTE



Knife blades that have not been cleaned contaminate the felt polishing wheel.

⇒ Before polishing, carefully clean the knife blade.

1. Position the knife on the machine so that the blade cutting edge points in the direction of rotation of the polishing wheel **[13-1]**.

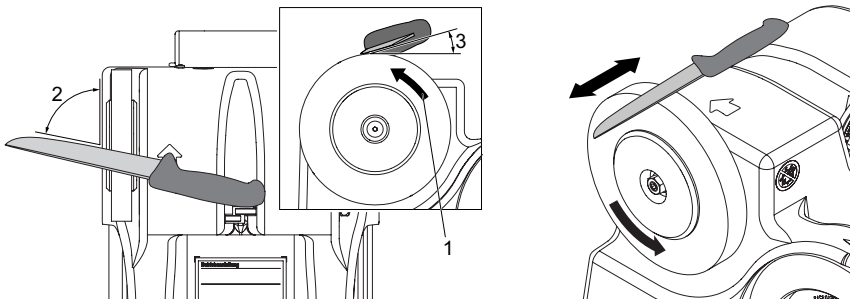

Image 13 – Positioning the knife on the polishing wheel

[13-1] Direction of rotation of the polishing wheel

[13-2] Positioning angle slanted relative to the running direction (approx. 30°–60°)

[13-3] Positioning angle to the polishing wheel

2. Apply polishing paste on the running polishing wheel.
3. Clean the knife before polishing.
 - ⇒ The blade must be dry for polishing.
4. Position the knife slanted relative to the running direction.
 - ⇒ Position the knife at the polishing wheel at a more obtuse angle than for grinding.

5. Start the polishing movement at the handle and continue to the tip of the blade. Make three to four passes alternately on each side of the blade under light pressure until the surface has reached the desired degree of polishing.
6. Clean the knife after polishing.

8 Servicing and maintenance

WARNING



RISK OF INJURY DUE TO UNAUTHORISED OR CARELESS SWITCHING ON

If the machine is still connected to the mains during maintenance or repair work, there is a risk of it being switched on carelessly and causing injury.

⇒ Always disconnect the mains plug before carrying out any maintenance or repair work.

WARNING



RISK OF INJURY DUE TO INCORRECT SPARE PARTS

Incorrect spare parts can damage the machine or cause parts to be flung away, potentially causing serious injury.

⇒ Use exclusively original spare parts from Friedr. Dick GmbH & Co. KG.

WARNING



RISK OF INJURIES DUE TO IMPROPER REPAIR WORK

Improper repairs may limit or alter the functioning and result in electric shock or serious injury.

⇒ Repair work on electric components may only be carried out by qualified electricians.

⇒ Do not carry out any unauthorised repairs or modifications.

NOTE



CHECK THAT THE PARTS HAVE BEEN FULLY INSTALLED

After finishing all repairs and servicing work, check that all dismantled parts have been completely and correctly installed, especially the covers.

8.1 Clean the machine

The machine must be cleaned after each work session. In order to obtain good grinding results at all times, always keep the machine clean, especially the knife guides.

CAUTION



RISK OF INJURY FROM ROTATING MACHINE PARTS

If the machine is accidentally switched on during maintenance work, there is a risk of injury due to rotating machine parts.

⇒ Always pull the mains plug before carrying out any maintenance work.

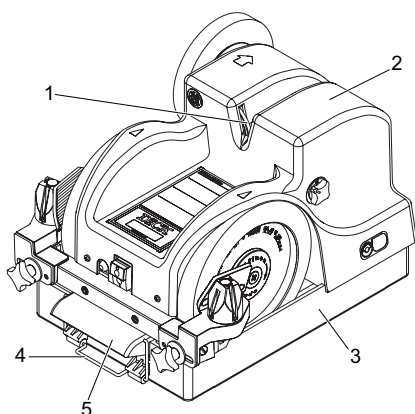

[14-1] Honing wheels

[14-2] Plastic housing

[14-3] Water tank

[14-4] Clamp

[14-5] Handle

Image 14 – Clean the machine

1. Remove residual abraded material from the machine, e.g. using a brush.
2. Depending on the degree of contamination, clean the honing wheels [14-1] with a cleaning cloth soaked in washing-up liquid or alcohol. While doing so, turn the honing wheels by hand.
3. Clean the plastic housing [14-2] from grinding dust only with a soft brush.
⇒ Abrasive grains cause scratches on the housing even when using a soft cloth.
4. Clean the water tank [14-3] daily after use and keep it dry. To this end, open both clamps [14-4] and lift the machine out of the water tank using both handles [14-5].

8.2 Dressing the grinding wheel

If the grinding wheels are very dirty or if there is noticeable lateral runout (imbalance), the grinding wheels need to be dressed. The dressing device consists of: Dressing spindle with diamond, swivel lever and retaining screw.

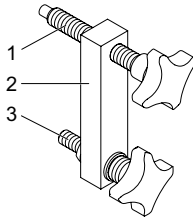

- [15-1] Dressing spindle with diamond
- [15-2] Swivel lever
- [15-3] Retaining screw

Image 15 – Dressing device

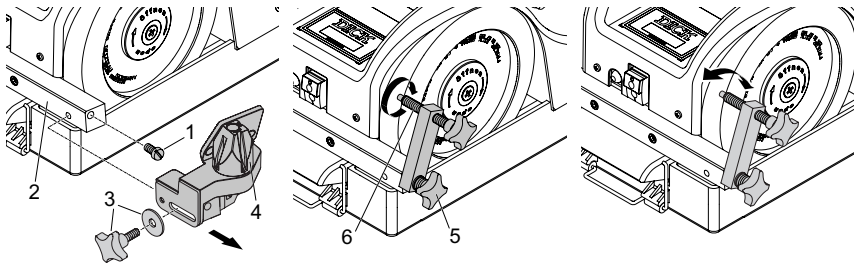

Image 16 – Dressing the grinding wheels

- [16-1] Screw plug
- [16-2] Guidance
- [16-3] Star handle screw and washer
- [16-4] Knife guide
- [16-5] Dressing device with retaining screw
- [16-6] Dressing spindle

1. Lift the machine out of the water tank.
2. Remove the screw plug [16-1] on the front side of the guide [16-2]. Remove star handle screw and washer [16-3] and pull off the knife guide [16-4].
3. Attach the dressing device with retaining screw [16-5] and tighten firmly.
4. Put the machine back into the water tank.
5. Before switching on the machine, make sure that the dressing spindle [16-6] and the diamond are not touching the grinding wheel.

NOTE

Never dry dress the grinding wheel.

6. Dressing process: Switching on the machine. Turn the dressing spindle **[16-6]** towards the lateral grinding surface of the grinding wheel until the diamond touches it.
7. Slowly swivel the pivot lever to the right and left until the diamond no longer grips. Adjust the dressing spindle slightly clockwise and continue the dressing process until the grinding surface is clean or runs without lateral run out. Dismantle the dressing device again after the dressing process. Fit the screw plug and knife guide again and clean the machine.

8.3 Removing the grinding wheels

Turn around grinding wheels that are worn or damaged on one side. Replace grinding wheels that are worn or damaged on both sides with new ones. Grinding wheels are worn when the edge **[17-A]** on the lateral grinding surfaces is no longer present.

CAUTION**RISK OF INJURY FROM ROTATING MACHINE PARTS**

If the machine is accidentally switched on during maintenance work, there is a risk of injury due to rotating machine parts.

⇒ Always pull the mains plug before carrying out any maintenance work.

1. Pull the mains plug
2. Open both clamps **[17-1]**.
3. Lift the machines out of the water tank by both handles **[17-2]**.

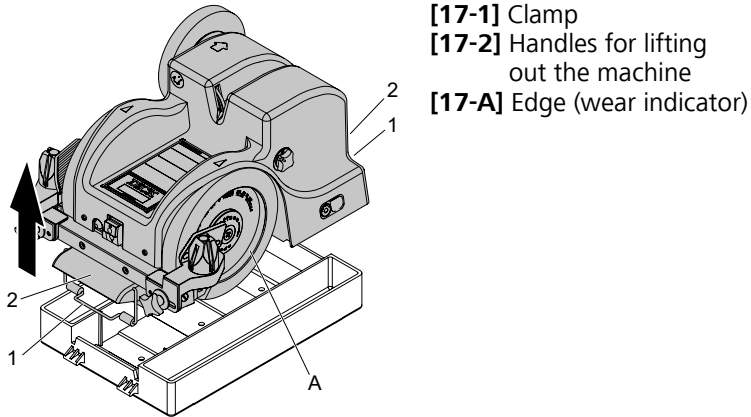

- [17-1] Clamp
- [17-2] Handles for lifting out the machine
- [17-A] Edge (wear indicator)

Image 17 – Lift the machine out of the water tank by both handles

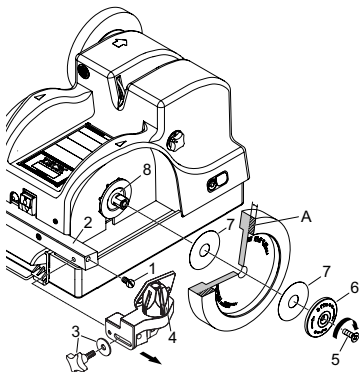

- [18-1] Screw plug
- [18-2] Guidance
- [18-3] Star handle screw and washer
- [18-4] Knife guide
- [18-5] Fastening screw
- [18-6] Flange cover
- [18-7] Plastic disc
- [18-8] Centring flange
- [18-A] Edge (wear indicator)

Image 18 – Remove grinding wheels

4. Remove the screw plug [18-1] on the front side of the guide [18-2].
5. Remove the star handle screw and washer [18-3] and pull off knife guide [18-4].
6. Hold the grinding wheel and loosen the mounting bolt [18-5] with the enclosed hexagonal spanner size 5 in direction of rotation of the grinding wheel.
7. Remove flange [18-6] and plastic disc [18-7] and pull off the grinding wheel from the centring flange [18-8]. Make sure that the inner plastic disc [18-7] remains on the centring flange.

Proceed in the same way for the opposite side.

8.3.1 Additional steps if the grinding wheel is stuck

[19-1] Lever

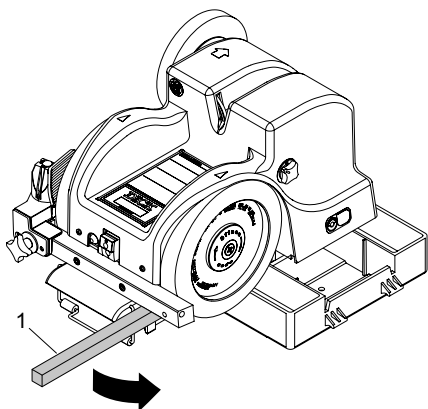

Image 19 – Loosen stuck grinding wheel

1. Push the lever or similar [19-1] between chassis and grinding wheel and press it carefully against the inside of the grinding wheel.
2. Rotate the grinding wheel by 90° and repeat the process until the grinding wheel has detached from the centring flange.

8.4 Installing the grinding wheels

When installing new grinding wheels, also install the enclosed plastic discs. When turning around the previous grinding wheels, replace the enclosed plastic discs.

1. Carry out the steps for removal (see 8.3 Removing the grinding wheels) in reverse order.

NOTE



There is a difference between right and left flange cover. Direction arrow from the flange cover must match the one on the machine.

2. In order to ensure good and safe knife guidance, place knife guides as close as possible to the grinding wheels without touching them. (see 6.4.1 Adjusting the knife guides (grinding angle))
3. Insert the mains plug.
4. Switch on the machine and test run it for one minute. In case of unusual behaviour, switch off the machine immediately and check all individual parts for proper condition and assembly.

5. Check lateral runout before test run. If necessary, open the screw and turn the grinding wheel a little further.
6. Repeat the process until the grinding wheel runs, if necessary dress the grinding wheel. (see 8.2 Dressing the grinding wheel).

8.5 Remove the honing wheels

Damaged honing wheels (e.g. breakage, cracks, nicks) must be replaced.

CAUTION



RISK OF INJURY FROM ROTATING MACHINE PARTS

If the machine is accidentally switched on during maintenance work, there is a risk of injury due to rotating machine parts.

⇒ Always pull the mains plug before carrying out any maintenance work.

1. Pull the mains plug.
2. SM-110: Continue with step 5

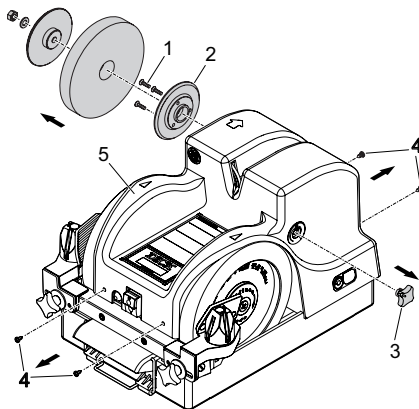

Only for SM-111

- [20-1] Countersunk screws
- [20-2] Flange incl. fitting screw
- [20-3] Star handle

SM-110 and SM-111

- [20-4] Screws on the end faces of the housing
- [20-5] Housing

Image 20 – Remove the honing wheels

Only for SM-111:

3. Remove polishing wheel (see 8.7 Replacing the polishing wheel (only for SM-111)).
4. In addition, unscrew the three countersunk screws [20-1] with the enclosed Phillips screwdriver and remove the flange [20-2] incl. the fitting screw. Pull off the star handle [20-3].

SM-110 and SM-111:

5. Unscrew the four screws **[20-4]** on the front sides of the housing with the enclosed Phillips screwdriver and lift the housing **[20-5]** upwards.

NOTE



REPLACE HONING WHEELS ALWAYS IN PAIRS.

First remove the left, then the right honing wheel.

The honing wheels are permanently glued to the flanges (flanges cannot be dismantled).

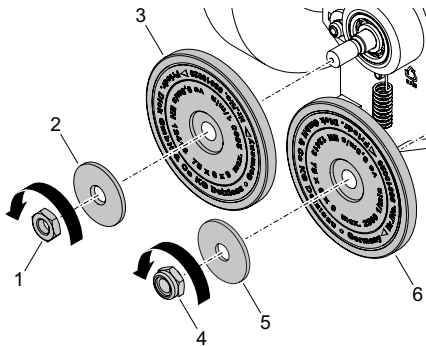

- [21-1]** Nut
- [21-2]** left flange disc
- [21-3]** left honing wheel with flange
- [21-4]** Locking nut
- [21-5]** right flange disc
- [21-6]** right honing wheel with flange

Image 21 – Remove the honing wheels

6. Unscrew the nut **[21-1]** on the honing wheel shaft in the direction of rotation of the honing wheel using the enclosed ring spanner size 13, while holding the honing wheel by hand to prevent it from turning.
7. Remove the left flange disc **[21-2]** and honing wheel **[21-3]** from the shaft.
8. Screw the locking nut **[21-4]** on the honing wheel shaft against the direction of rotation of the honing wheel, while holding the honing wheel to prevent it from rotating.
9. Remove the right flange disc **[21-5]** and honing wheel **[21-6]** from the shaft.

8.6 Installing the honing wheel

1. Put a new honing wheel with short flange [21-6] onto the right shaft. Direction of rotation arrow/labelling must point forwards.
2. Put the flange disc [21-5] onto the shaft and screw on locking nut [21-4]. Hold the shaft in place to prevent it from rotating.
3. Put a new honing wheel with a long flange [21-3] onto the left shaft. Direction of rotation arrow/labelling must point forwards.
4. Put the flange disc [21-2] onto the shaft and screw on the nut [21-1]. Hold the shaft in place to prevent it from rotating.
5. Put on the housing [22-5] screw in four screws [22-4] on the end faces of the of the housing with the enclosed Phillips screwdriver.

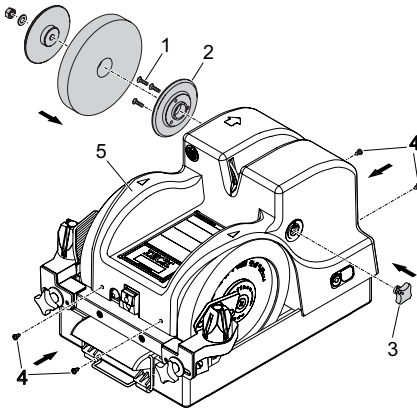

Only for SM-111

- [22-1] Countersunk screws
- [22-2] Flange incl. fitting screw
- [22-3] Star handle

SM-110 and SM-111

- [22-4] Screws on the end faces of the housing
- [22-5] Housing

Image 22 – Installing the honing wheel

6. SM-110: Continue with step 11.

Only for SM-111:

7. In addition, fit star handle [22-3].
8. Install flange [22-2] incl. fitting screw.
9. Screw in the three countersunk screws [22-1] with enclosed Phillips screwdriver.
10. Installing the polishing wheel (see 8.7 Replacing the polishing wheel (only for SM-111)).

SM-110 and SM-111:

11. Insert the mains plug.
12. Switch on the machine and test run it for one minute. In case of unusual

behaviour, switch off the machine immediately and check all individual parts for proper condition and assembly.

8.7 Replacing the polishing wheel (only for SM-111)

A worn or damaged polishing wheel (e.g. breakage, nicks, severe imbalance, severe radial runout) must be replaced.

CAUTION



RISK OF INJURY FROM ROTATING MACHINE PARTS

If the machine is accidentally switched on during maintenance work, there is a risk of injury due to rotating machine parts.

⇒ Always pull the mains plug before carrying out any maintenance work.

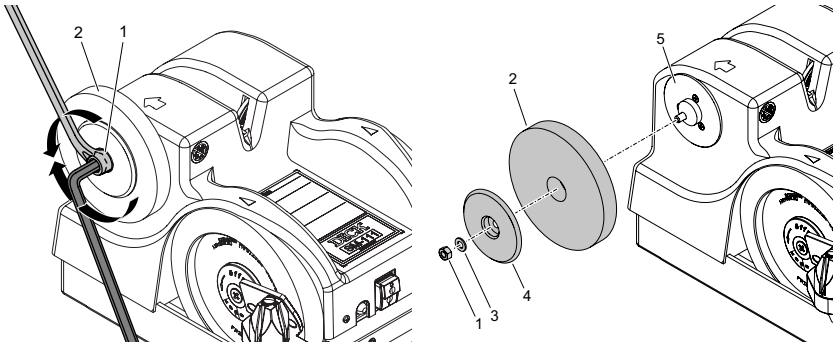

Image 23 – Changing the polishing wheel

[23-1] Nut

[23-2] Polishing wheel

[23-3] Washer

[23-4] Flange disc

[23-5] Flange

1. Remove the nut [23-1] on the polishing wheel shaft with enclosed ring spanner size 13 in direction of rotation of the polishing wheel [23-2]. Hold the shaft with the enclosed Allen key to prevent it from rotating.
2. Pull the washer [23-3] from the shaft and the polishing wheel [23-2] from the flange [23-5].
3. Remove the flange [23-4] from the polishing wheel and press it into the new polishing wheel.

4. Install the polishing wheel in reverse order.
5. Insert the mains plug.
6. Switch on the machine and test run it for one minute. In case of unusual behaviour, switch off the machine immediately and check all individual parts for proper condition and assembly.

8.8 Check and replace drive belt

If the respective wheel(s) stop during the honing or polishing process, check the belt and replace if necessary.

8.8.1 Dismantling the housing

CAUTION



RISK OF INJURY FROM ROTATING MACHINE PARTS

If the machine is accidentally switched on during maintenance work, there is a risk of injury due to rotating machine parts.

⇒ Always pull the mains plug before carrying out any maintenance work.

1. Pull the mains plug
2. SM-110: Continue with step 5

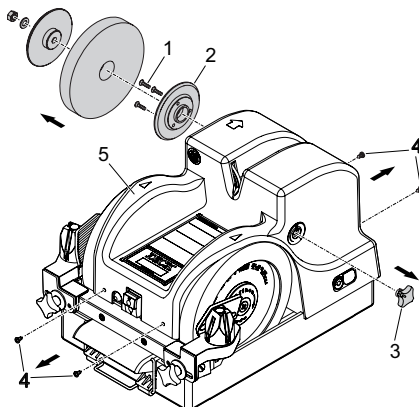

Only for SM-111

- [24-1] Countersunk screws
- [24-2] Flange incl. fitting screw
- [24-3] Star handle

SM-110 and SM-111

- [24-4] Screws on the end faces of the housing
- [24-5] Housing

Image 24 – Dismantling the housing

Only for SM-111:

3. Remove polishing wheel (see 8.7 Replacing the polishing wheel (only for SM-111)).

- In addition, unscrew the three countersunk screws [24-1] with the enclosed Phillips screwdriver and remove the flange [24-2] incl. the fitting screw. Pull off the star handle [24-3].

SM-110 and SM-111:

- Unscrew the four screws [24-4] on the end faces of the housing with the enclosed Phillips screwdriver and lift the housing [24-5] upwards.

8.8.2 Checking the belt condition

The belts must not be porous or greasy.

NOTE



THE DRIVE BELTS MUST ALWAYS BE FULLY TENSIONED.

If the machine has been exposed to temperatures below +5 °C for a longer period of time, the tension of the belts is temporarily reduced. After about one minute of running without load, the full performance of the belts is restored.

8.8.3 Replacing the flat belt

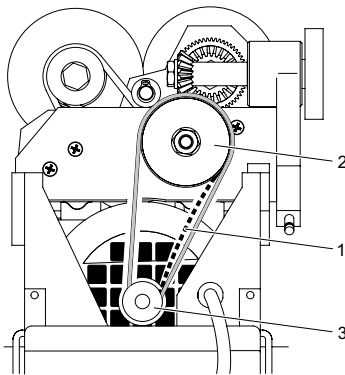

- [25-1] Flat belt
- [25-2] large flat belt pulley
- [25-3] small flat belt pulley

Image 25 – Replacing the flat belt

- First remove the belt [25-1] from the large, upper flat belt pulley [25-2].
- First place the new belt over the small, lower belt pulley [25-1] and then pull it over the large, upper one.
 - ⇒ The textile side of the flat belt must face outwards.

8.8.4 Replacing the round belt

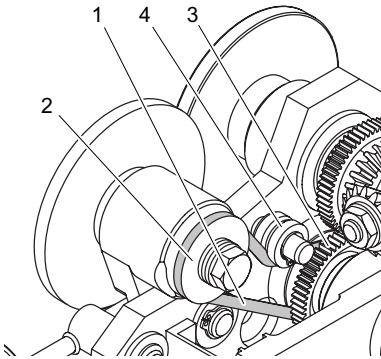

- [26-1] Round belt
- [26-2] Upper belt pulley
- [26-3] Lower belt pulley
- [26-4] Deflection roller

Image 26 – Replacing the round belt

1. First remove the round belt [26-1] from the upper belt pulley [26-2].
2. First place the new round belt over the lower pulley [26-3], guide past the deflection roller [26-4] at the bottom and pull it over the upper belt pulley.

8.8.5 Installing the housing

1. Put on the housing [27-5] screw in four screws [27-4] on the end faces of the housing with the enclosed Phillips screwdriver.

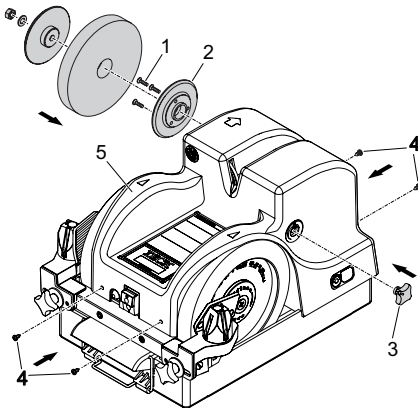

Only for SM-111

- [27-1] Countersunk screws
- [27-2] Flange incl. fitting screw
- [27-3] Star handle

SM-110 and SM-111

- [27-4] Screws on the end faces of the housing
- [27-5] Housing

Image 27 – Installing the housing

2. SM-110: Continue with step 7.

Only for SM-111:

3. In addition, attach the star handle [27-3].
4. Install the flange [27-2] incl. fitting screw.
5. Screw in the three countersunk screws [27-1] with the enclosed Phillips screwdriver.
6. Installing the polishing wheel (see 8.7 Replacing the polishing wheel (only for SM-111)).

SM-110 and SM-111:

7. Insert the mains plug.
8. Switch on the machine and test run it for one minute. In case of unusual behaviour, switch off the machine immediately and check all individual parts for proper condition and assembly.

8.9 Replacing water stripping brush

If the grinding wheels splash water, check the position and condition of the brushes [28-1] on the knife guides [28-5]. Worn water stripping brushes must be replaced. Always replace the left and right brush units at the same time, as both wear out equally.

CAUTION



RISK OF INJURY FROM ROTATING MACHINE PARTS

If the machine is accidentally switched on during maintenance work, there is a risk of injury due to rotating machine parts.

⇒ Always pull the mains plug before carrying out any maintenance work.

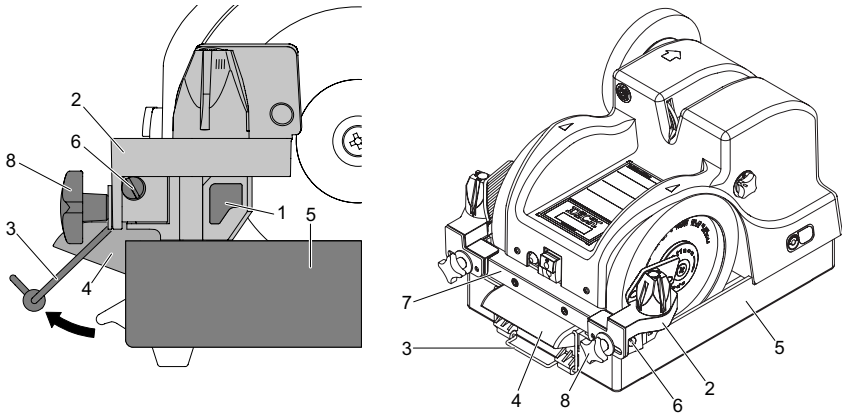

Image 28 – Replacing water stripping brush

- [28-1] Water stripping brush
- [28-2] Knife guide
- [28-3] Clamp
- [28-4] Handles for lifting out the machine
- [28-5] Water tank
- [28-6] Screw plug
- [28-7] Guidance
- [28-8] Star handle screw and washer

1. Open both clamps [28-3].
2. Lift the machine out of the water tank [28-5] by the two handles [28-4].
3. Remove the screw plug [28-6] on the front side of the guide [28-7].
4. Remove the star knob screw and washer [28-8].
5. Pull off the knife guide [28-2].

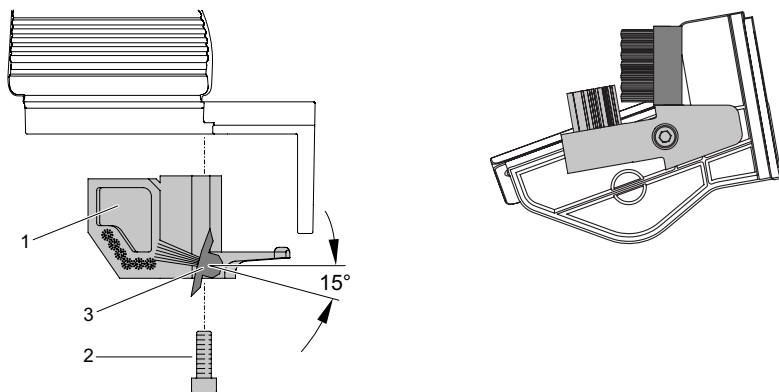

Image 29 – Replacing water stripping brush

[29-1] Brush unit

[29-2] Screw

[29-3] Brush position between 0 and 15°

[29-4] Deflection roller

6. Unscrew the screw **[29-2]** with enclosed Allen key (size 4).
7. Replace the complete brush unit **[28-1]** and **[29-1]**.
 - ⇒ Pay attention to the right brush position **[29-3]**, between 0 and 15°.
 - ⇒ If necessary, correct the brush position by turning it.
8. Reassemble the knife guides **[28-2]** in reverse order. Screw in the screw plugs **[28-6]** on the face ends of the guide **[28-7]**.
9. In order to ensure good and safe knife guidance, place knife guides as close as possible to the grinding wheels without touching them (see 6.4.1 Adjusting the knife guides (grinding angle))
10. Insert the mains plug.
11. Switch on the machine and test run it for one minute. In case of unusual behaviour, switch off the machine immediately and check all individual parts for proper condition and assembly.

9 Fault – cause – remedy

Fault	Cause	Remedy
Mains plug inserted. Main switch "ON". Machine does not run (grinding wheels do not turn).	There is no mains voltage. Motor/switch/cable defective.	Have the fault remedied by a qualified electrician.
	Circuit breaker tripped.	Press in the circuit breaker (see 6.5 Control elements on the machine).
	Grinding wheels are clamped by the knife guide.	Correctly adjust the knife guides (see 6.4.1 Adjusting the knife guides (grinding angle)).
When the machine is switched on, the grinding wheels rotate, the honing wheels do not rotate.	Flat belt has come off the belt pulley or is defective.	Refit the flat belt or replace (see 8.8.3 Replacing the flat belt).
Only one honing wheel turns when the machine is switched on.	Round belt has come off the belt pulley or is damaged.	Refit the round belt or replace (see 8.8.4 Replacing the round belt).
The grinding result on the knife is not satisfactory after the honing process.	The honing process has not been carried out until the entire knife edge has a burr.	Repeat the grinding process until the entire knife edge shows a burr (see 7.1 Knife sharpening), then hone the knife (see 7.2 Honing knives).
Grinding bevel on the resharpened knife is too wide.	Incorrect operation: The blade is not in full contact with the magnet when it is pulled through between the grinding wheel and the magnet.	Repeat the grinding process and make sure that the blade lies flat against the magnet (see 7.1 Knife sharpening).

10 Spare parts

A spare parts drawing and a spare parts list are available at www.dick.de.

CAUTION



RISK OF INJURY DUE TO INCORRECT SPARE PARTS

The use of parts other than original spare parts poses an unpredictable risk that may result in injuries.

⇒ Use exclusively original spare parts from Friedr. Dick GmbH & Co. KG.

When ordering spare parts, please select the parts to be replaced from the spare parts list available on the internet, including the order number and name.

Please send your order for spare parts to your specialist dealer. You can find your specialist dealer at:
www.dick.de/de/koch-und-fleischerwerkzeuge/haendler



Your order must include the following details:

1. Required quantity,
2. Order number,
3. Name,
4. Machine type, machine article number, serial number, year of manufacture (see type plate).

11 Accessories

Description	Order number
Grinding support for sharpening household scissors	9 8153 010

CAUTION



RISK OF INJURY DUE TO INCORRECT SPARE PARTS

The use of parts other than original spare parts poses an unpredictable risk that may result in injuries.

⇒ Use exclusively original accessories from
Friedr. Dick GmbH & Co. KG.

12 EC Declaration of Conformity

(only for 230 V version)

Manufacturer
Friedr. Dick GmbH & Co. KG
Esslinger Str. 4–10
73779 Deizisau, Germany
GERMANY

We hereby declare in sole responsibility that the products

- Knife grinding and honing machine - Type SM-110
- Knife grinding and honing machine - Type SM-111

with the serial numbers indicated on the type plates of the machines, conform to the following EC directives:

- EC Machinery Directive (2006/42/EC)
- EMC Directive (2014/30/EU)
- RoHS Directive (2011/65/EU)

European standards applied:

- EN ISO 12100:2010
- EN 60204-1:2018
- EN IEC 61000-3-2:2019
- EN 61000-3-3:2013 + A1:2019
- EN IEC 63000:2018
- EN 55014-1:2017
- EN 55014-2:2015

The person authorised to compile technical documentation at Friedr. Dick GmbH & Co. KG is Mr Steffen Uebele, Managing Director.





